

Solid State Drive (SSD)

Environmental Testing Report and Certification

Testing Details

Document Name	Environmental Test Report and Certification
Company Name	Super Talent Technology
Sample Name(s)	SATA 2.5" SSD
	IDE 2.5" SSD
Model Name(s)	FSD32GC32M
	SS32A6C35M
Date of Test	October 24, 2007 – November 7, 2007
Document Status	Released
Last Updated On	October 13, 2008
Last Updated By	Yelena Pesic

Document History

Revision	Release Date	Author	Purpose and/or Desc. Of Changes
1.0	11/27/07	Yelena Pesic	First Revision
2.0	7/1/08	Yelena Pesic	Compliance Letter Update
3.0	10/13/08	Yelena Pesic	Minor Edits

Table of Contents

Introduction.....	3
Vibration Test Procedure.....	3
Description of Test Apparatus.....	3
Mechanical Shock Test Procedure	5
Temperature/Humidity Test Procedure	7
Mechanical Drop Test Procedure.....	8
RoHS Test Procedure	10
FCC Test Procedure	11
CE Test Procedure.....	13
RoHS Certification - SATA.....	15
RoHS Certification - IDE	16
FCC Certification – SATA.....	17
FCC Certification – IDE	18
CE Certification - SATA	19
CE Certification - IDE.....	20
RoHS, FCC, CE Verification of Compliance for all Solid State Drives.....	21

Introduction

Super Talent Technology designs and manufactures the world's most rugged SSDs, combining technology, performance and reliability to make a truly outstanding storage device. Our drives are the next generation product for data storage since they are genuinely state-of-the-art vibration and shock tolerant. In order to confirm our claim, we used an independent testing lab to validate our published reliability specs for our SSD product line.

We asked a third-party testing lab to qualify the SSDs with our given individual rated values for the vibration, mechanical shock, temperature/humidity, and mechanical drop. Our specifications are industry standard values for a rugged and reliable product. If the test passed, we are then able to endorse our SSD at that value. We also qualified our drives for RoHS, FCC, and CE certification. This whitepaper reviews the testing methodology with a summary of our test data to prove Super Talent's SSDs meet industry and enterprise class standards, as well as a brief description and compliance letters for RoHS, FCC, and CE certification.

Vibration Test Procedure

The SSD was able to perform at our given rated value of 16G with force equal to 600Kgf applied in the X, Y, and Z-axis for a test time of one hour.

Description of Test Apparatus

Apparatus Name:	KING DESIGN Vibration Test System
Model:	EM-600F2K-40N120
Rated Force:	600Kgf
Frequency Range:	2~2,000Hz (DC)
Acceleration Max:	60G
Displacement Max:	40mm
Velocity max:	220cm/sec
Test Name:	DACTRON Vibration Control System

Laboratory Ambience Condition

Temperature:	25 ± 5°C
Humidity:	60 ± 5%RH

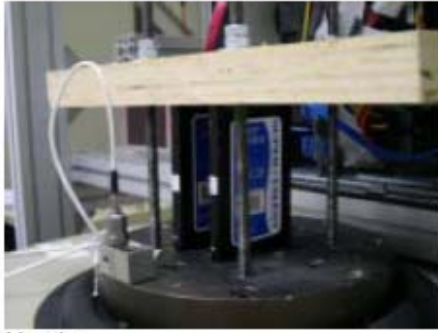

X axis

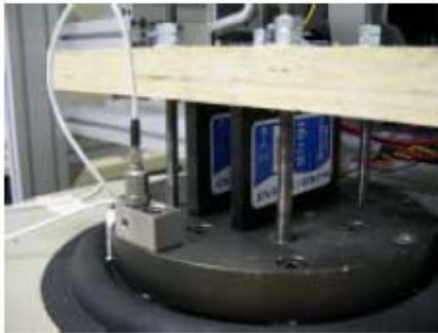
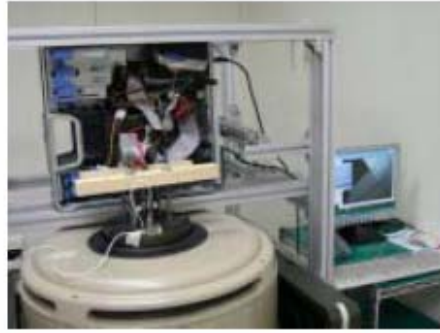

Y axis

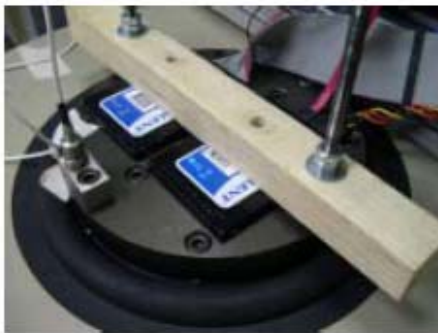
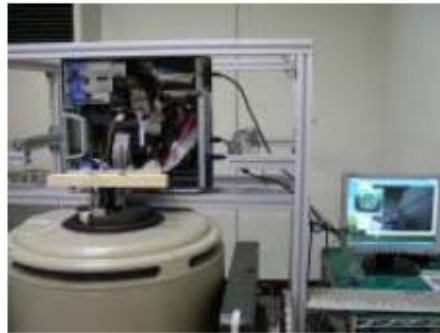

Z axis

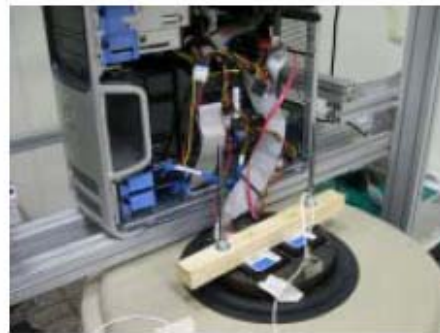

Figure 1: Vibration Tests shown in the X, Y, and Z Axis

Super Talent's SSDs are able to withstand a 16G vibration value because there are no moving parts. The value is more than five times greater vibration resistance compared to an average hard disk drive, which can only withstand an average 1G vibration value.

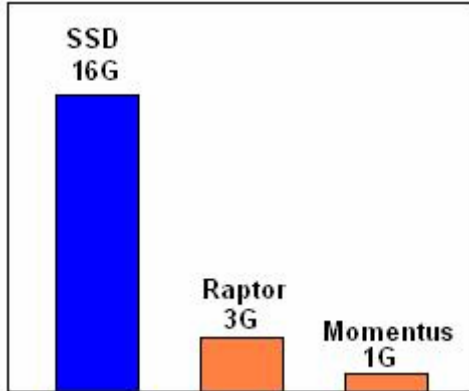

Figure 2: SSD and HDD Vibration Comparison

Figure 2 demonstrates the startling difference in which Super Talent's SSD vibration value surpasses two popular HDDs, Western Digital's Raptor and Seagate's Momentus. This gives the SSD an edge in harsh environments where conventional hard disk drives are at a high risk of failure.

Mechanical Shock Test Procedure

The SSD met its rated shock value of 1500G under the following test specifications with shock applied on the X, Y, and Z-axis.

Description of Test Apparatus

Apparatus Name:	Vibration Source Shock Tester
Model:	SHOCK-2
Rated Force:	10kg
Acceleration:	30~1500G
Pulse Duration:	0.2~11ms
Table Dimension:	280 x 210 mm

Laboratory Ambient Conditions

Temperature:	25 ± 5°C
Humidity:	60 ± 5%RH

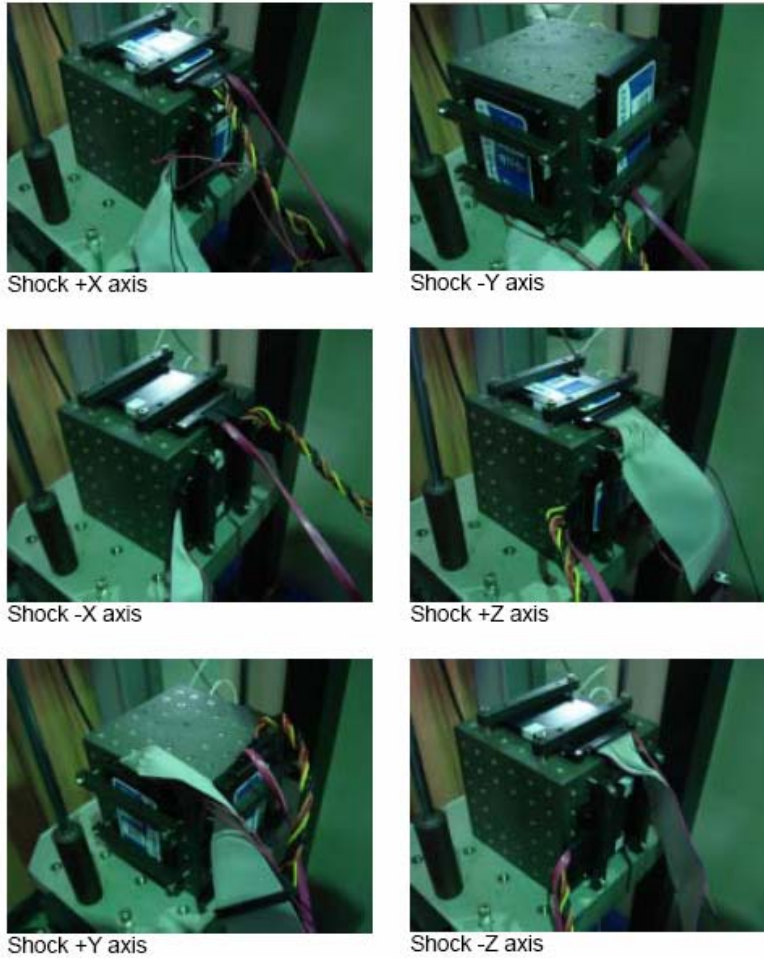

Figure 3: Shock Tests shown in the \pm X, Y, Z Axis

In shock resistance tests, moving parts are the Achilles heel of legacy hard disks. The solid-state architecture of the SSD allows it to withstand a 1500G shock. This is five times greater than a typical HDD, which on average can only withstand a shock of 300G.

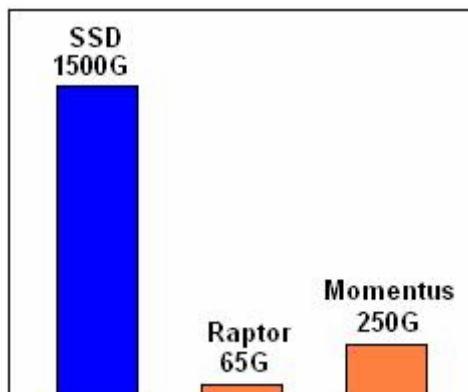

Figure 4: SSD and HDD Shock Value Comparison

Figure 4 illustrates that Super Talent's SSD is the superior product when a reliable data storage product is needed.

Temperature/Humidity Test Procedure

The SSD was able to perform in the industry standard temperature range of -40°C to 85°C (operational) when tested under the following test specifications. The transfer time is 1°C/min with a total test time of 52 hours.

Description of Test Apparatus

Apparatus Name:	Tempe/Low Humidity Chamber
Manufacturer:	KSON THS-D
Temperature Range:	-40°C ~ 100°C
Humidity Range:	5% ~ 98% RH
Ramp Rate:	0.8~3°C/min
Chamber Capacity:	100*80*100 cm (W*D*H)
Date of Last Calibration:	October 29, 2007
Date of Calibration Due:	October 29, 2008

Laboratory Ambient Conditions

Temperature:	25 ± 5°C
Humidity:	60 ± 5%RH



Figure 5: Temperature/Humidity Testing Chamber

Once again, the SSD with no moving can go places the HDD can't. Compare these results with hard disk drives in figure 6,

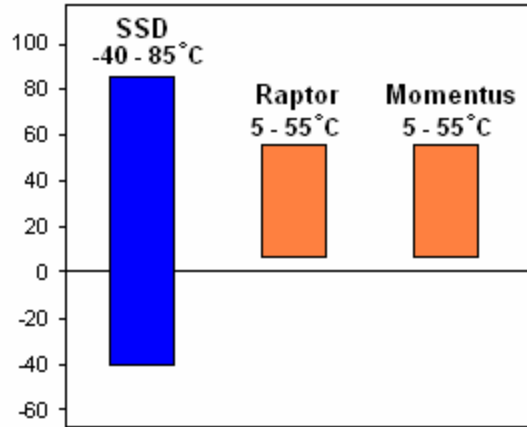

Figure 6: SSD and HDD Temperature Comparisons

The Raptor HDD and the Momentus HDD can only tolerate temperatures between 5°C and 55°C. The range is significantly less than Super Talent’s SSD. A large operable temperature range is important in industrial applications in which the environments have extreme weather conditions.

Mechanical Drop Test Procedure

The tough mechanical casing enhances the rugged feature of the SSD; it can be dropped in any direction from a height of at least 100cm.

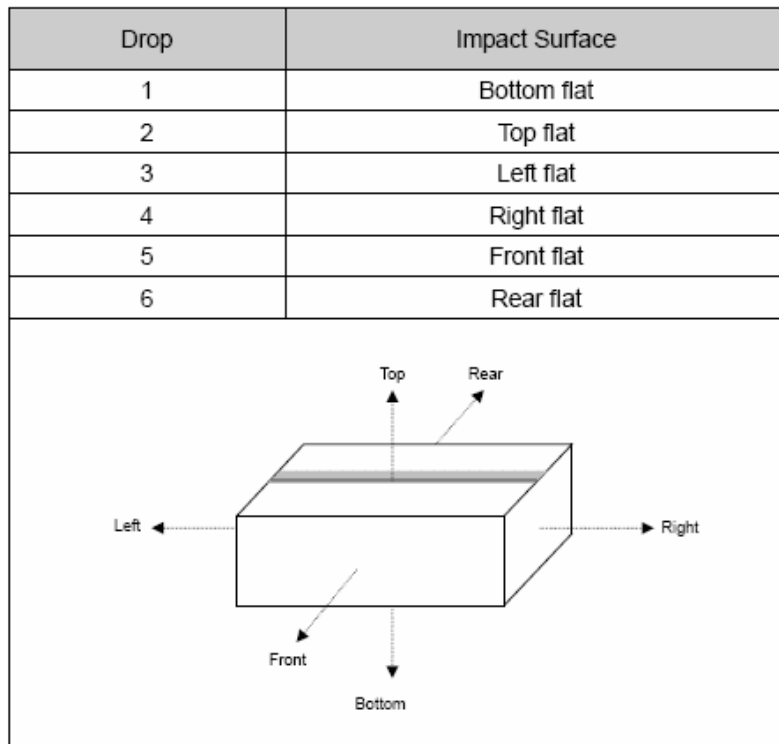

Figure 7: Test Procedure for Mechanical Drop Test

An unexpected fall can spell the end of a conventional hard drive. The drop test shows that the Super Talent SSD won't lose your data when it hits the floor. The drop test was performed under the following test specifications.

Description of Test Apparatus

Apparatus Name:	KING DESIGN Drop Tester
Model:	KD128A
Payload Capacity:	60kg
Payload Dimension:	80 x 80 x 80cm
Drop Height Range:	30 ~ 180cm
Base Plat Size:	85 x 150cm

Laboratory Ambient Conditions

Temperature:	25 ± 5°C
Humidity:	60 ± 5%RH

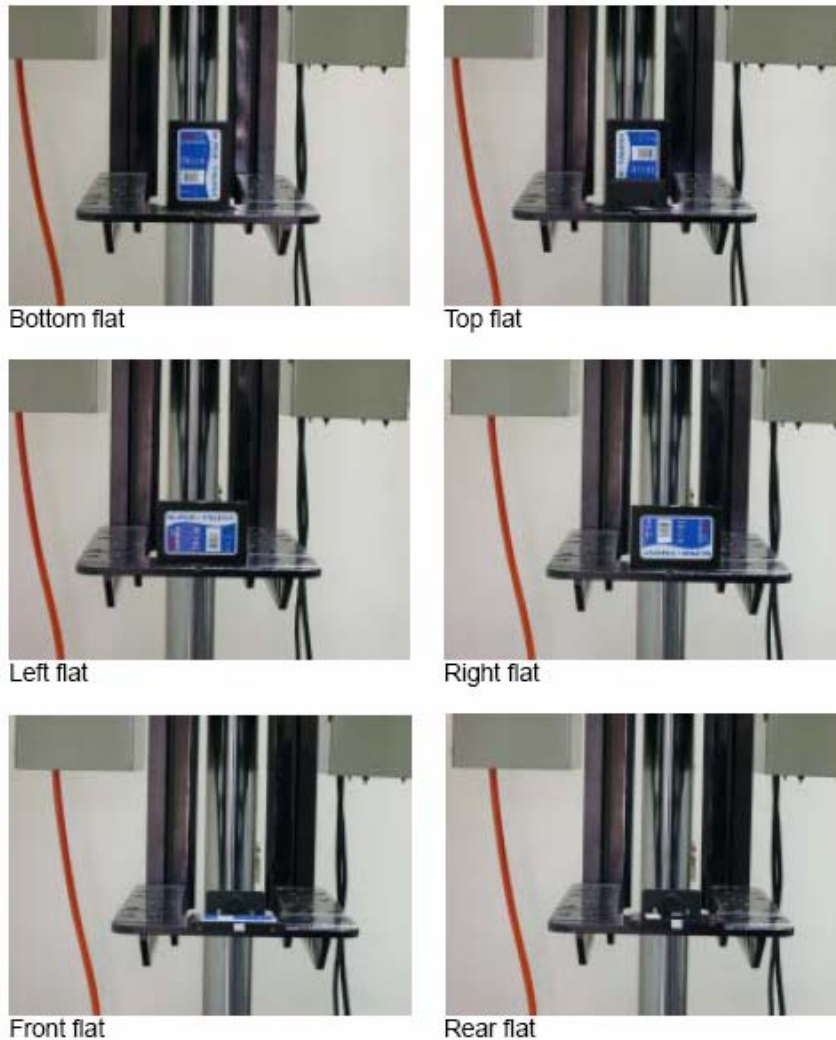

Figure 8: Mechanical Drop Test shown in all directions

The mechanical casing enhances the rugged feature of the SSD and with moving no moving parts; it can be dropped in any direction from a height of at least 100cm. There is no comparison to the HDD, when if dropped, will lose all its data and become non-operable.

RoHS Test Procedure

As an environmentally friendly company, we tested our SSDs to be compliant with *Directive 2002/95/EC on Restriction of the Use of Certain Hazardous Substance (RoHS) in Electrical and Electronic Equipment*. Figure 9 shows the RoHS testing methods.

Analytical Substance	Equipment	Methods	MDL (ppm)	XRF Screening Action Limit * (ppm)
Pb	ICP-OES	US EPA 3051A US EPA 6010B	2	700
Cd	ICP-OES	US EPA 3051A US EPA 6010B	2	70
Hg	ICP-OES	US EPA 3051A US EPA 6010B	2	700
Cr ⁶⁺	UV-VIS	US EPA 3060A US EPA 7196A	2	700 (Cr)
PBBs	GC-MS	US EPA 3540C US EPA 8082	5	300 (Br)
PBDEs	GC-MS	US EPA 3540C US EPA 8082	5	300 (Br)

Figure 9: RoHS Testing Methods

In order to be meet RoHS requisites, the device must test for cadmium and its compounds, mercury and its compounds, hexavalent chromium and its compounds, lead and its compounds, polybrominated biphenyls (PBB), and polybrominated diphenyl ethers (PBDE).

The following list of acronyms and their meanings are shown to help analyze the RoHS test values. Figure 10 displays the RoHS test results.

MDL: Method Detection Limitation
 N.D: Not Detected < MDL
 PPM: mg/kg (0.1% = 1000 ppm)
 <: Less Than



Tested Part No.	XRF Screening (ppm)	Chemical Test (ppm)	Tested Part Description	Tested Part Photo
07-10-QAC-097-6	Pb : 0.0 Cd : 0.0 Hg : 0.0 Cr : 0.0 Br : 1494.8	PBBs : N.D. (<5) PBDEs : N.D. (<5)	IC - Body	
07-10-QAC-097-10	Pb : 0.0 Cd : 0.0 Hg : 61.4 Cr : 0.0 Br : 2163.5	PBBs : N.D. (<5) PBDEs : N.D. (<5)	IC - Body	
07-10-QAC-097-12	Pb : 0.0 Cd : 33.3 Hg : 0.0 Cr : 0.0 Br : 57979.9	PBBs : N.D. (<5) PBDEs : N.D. (<5)	PCBA	

Figure 10: RoHS Test Results

FCC Test Procedure

Super Talent’s SSDs were tested by an independent testing laboratory for *Federal Communications Commission* (FCC) certification. This is an official recognition by the American government for products that meet inbound and outbound radiation limits so it will not affect the communication of surrounding products.

Each SSD was tested as an independent unit. Figure 11 shows the configuration of the EUT as well as the support units used during the testing procedure. Table 2 lists the specific equipment for each support unit.

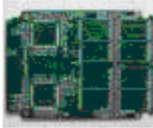
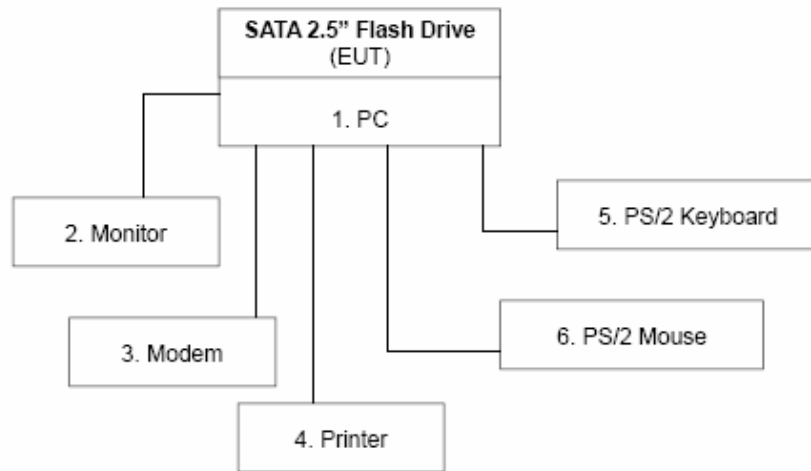

Figure 11: FCC Test Configuration

No.	Equipment	Model No.	Serial No.	FCC ID	Trade Name	Data Cable	Power Cord
1	PC	DX-7300	SGH73200	FCC DoC	HP	N/A	Unshielded, 1.8m
2	Monitor	959NF	AQ19H2RT706121B	FCC DoC	SAMSUNG	VGA Cable: Shielded, 1.8m with two cores	Unshielded, 1.8m
3	Modem	DM-1414	304012266	IFAXDM1414	ACEEX	Unshielded, 1.8m	Unshielded, 1.8m
4	Printer	STYLUS C60	DR3K039099	FCC DoC	EPSON	Shielded, 1.8m	Unshielded, 1.8m
5	PS/2 Keyboard	Y-SJ17	SY520U00642	FCC DoC	Logitech	Unshielded, 1.8m	N/A
6	PS/2 Mouse	M-SBF69	HCA45009245	FCC DoC	Logitech	Unshielded, 1.8m	N/A

Table 2: Summary of FCC Support Units

Table 3 lists outlines the results for the conducted and the radiated emissions for FCC certification. The results of each individual test are determined by the limit of each test standard.

EMISSION			
Standard	Item	Result	Remarks
FCC 47 CFR Part 15 Subpart B (August 14, 2006), ICES-003 Issue 4 ANSI C623.4-2003	Conducted (Main Port)	PASS	Meet Class B Limit
	Radiated	PASS	Meet Class B Limit

Table 3: FCC Test Results

Since the tests were not automatic, there is room for error. The measurement uncertainty can be seen in Table 4.

Measurement	Frequency	Uncertainty
Conducted Emission	9kHz – 30MHz	1.7806
Radiated Emissions	30 – 200MHz	3.8881
	200 – 1000MHz	3.8724

Table 4: Measurement Uncertainty

The uncertainty is determined by a 05% confidence level with $k = 2$, which is a standard method in determining limits.

CE Test Procedure

Super Talent’s SSDs were tested by a separate testing laboratory for *Conformité Européenne* (CE), which is a mandatory certification for the product to meet the safety, health, and environment requirements set by the European government. After testing, our SSDs are found to be compliant with the requirements set forth by the technical standards mentioned in Table 5.

Applicable Standards	EN 55022: 2006, Class B	EN 55024: 1998 + A1: 2001 _A2: 2003 IEC 61000-4-2: 1995 + A1: 1998 + A2: 2000 IEC 61000-4-3: 2002 + A1: 2002 IEC 61000-4-4: 2004
----------------------	-------------------------	---

Table 5: CE Applicable Standards

Each SSD was tested as an independent unit. Figure 12 shows the configuration of the EUT as well as the support units used during the testing procedure. Table 6 lists the specific equipment for each support unit.

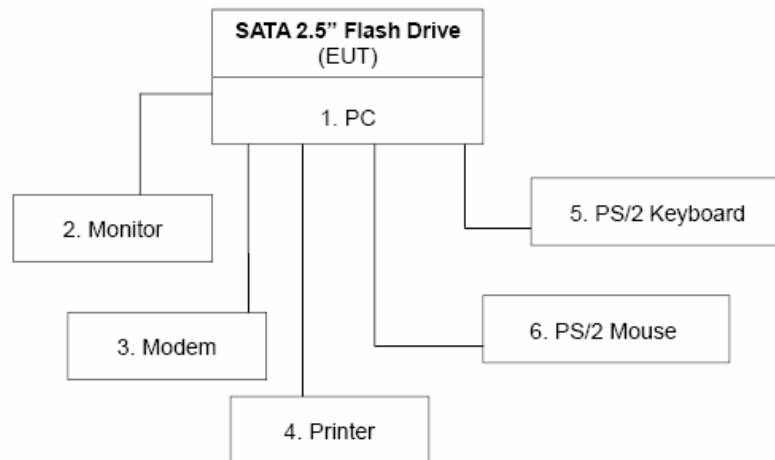

Figure 12: CE Test Setup

No.	Equipment	Model No.	Serial No.	FCC ID	Trade Name	Data Cable	Power Cord
1	PC	DX-7300	SGH73200V1	FCC DoC	HP	N/A	Unshielded 1.8m
2	Monitor	959NF	AQ19H2RT706 121B	FCC DoC	SAMSUNG	VGA Cable: Shielded, 1.8m with two cores	Unshielded 1.8m
3	Modem	DM-1414	304012266	IFAXDM14 14	ACEEX	Unshielded, 1.8m	Unshielded 1.8m
4	Printer	STYLUS C60	DR3K039099	FCC DoC	EPSON	Shielded, 1.8m	Unshielded 1.8m
5	PS/2 Keyboard	Y-SJ17	SY520UD0642	FCC DoC	Logitech	Unshielded, 1.8m	N/A
6	PS/2 Mouse	M-SBF69	HCA45009245	FCC DoC	Logitech	Unshielded, 1.8m	N/A

Table 6: Summary of CE Support Units

Table 7 is a synopsis of the results for the emission and immunity tests. The results of each individual test are determined by the limit of each test standard.

EMISSION			
Standard	Item	Result	Remarks
EN 55022: 2006	Conducted (Main Port)	PASS	Meet Class B limit
	Radiated	PASS	Meet Class B Limit

IMMUNITY [EN 55024 (1998 + A1: 2001 + A2: 2003]			
Standard	Item	Result	Remarks
IEC 61000-4-2: 1995 + A1: 1998 + A2: 2000	ESD	PASS	Meets the requirements of Performance Criterion B
IEC 61000-4-3: 2002 + A1: 2002	RS	PASS	Meets the requirements of Performance Criterion A
IEC 61000-4-4: 2004	EFT	PASS	Meets the requirements of Performance Criterion B

Table 7: CE Test Results

As with all tests, there is always a measurement uncertainty for each result. Table 8 lists the measurement uncertainty for figure 10.

Measurement	Frequency	Uncertainty
Conducted Emissions	9kHz – 30MHz	1.7806
Radiated Emissions	30 – 200MHz	3.8881
	200 – 1000MHz	3.8724

Table 8: Measurement Uncertainty

The uncertainty is determined by a 05% confidence level with $k = 2$, which is a standard method in determining limits.

Certificate

of Conformity for Directive 2002/95/EC (RoHS)

This is to certify enclosure(s) are in compliance with Directive 2002/95/EC on the Restriction of The Use of Certain Hazardous Substance (RoHS) in Electrical and Electronic Equipment.

Applicant: SUPER TALENT INC.

2075 N. Capital Ave. San Jose, CA 95132

Product/Sample: SATA 2.5" FLASH DRIVE

Style/Type: FSD16GC25M

Certificate No: 07-10-QAC-098

Date of Issue: November 16, 2007

This certificate of conformity is based on evaluated sample(s) of the product mentioned above. It does not imply the assessment of production of the product. The result of this evaluation is available on the RoHS Assessment Report, which is in conformity with 2005/618/EC Article 1, amending RoHS Directive 2002/95/EC.

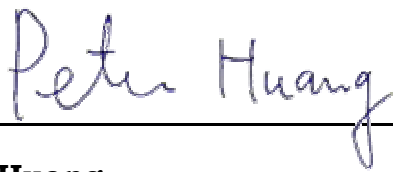

Peter Huang
Manager
Electronics Testing Center, Taiwan

Certificate

of Conformity for Directive 2002/95/EC (RoHS)

This is to certify enclosure(s) are in compliance with Directive 2002/95/EC on the Restriction of The Use of Certain Hazardous Substance (RoHS) in Electrical and Electronic Equipment.

Applicant: SUPER TALENT INC.

2075 N. Capital Ave. San Jose, CA 95132

Product/Sample: IDE 2.5" FLASH DRIVE

Style/Type: FHD16GC25M

Certificate No: 07-10-QAC-097

Date of Issue: November 5, 2007

This certificate of conformity is based on evaluated sample(s) of the product mentioned above. It does not imply the assessment of production of the product. The result of this evaluation is available on the RoHS Assessment Report, which is in conformity with 2005/618/EC Article 1, amending RoHS Directive 2002/95/EC.

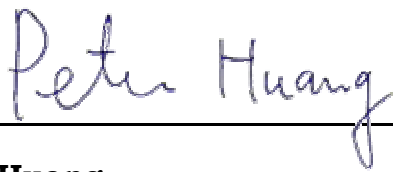

Peter Huang
Manager
Electronics Testing Center, Taiwan



VERIFICATION OF COMPLIANCE

This Verification of Compliance is hereby issued to the product designated below.

Product	SATA 2.5" Flash Drive
Model	FSD16GC25M
Trade name	Super Talent
Applicant	Super Talent Inc. 2075 N. Capital Ave. San Jose, CA 95132
Applicable Standard(s)	FCC 47 CFR PART 15 SUBPART B (Class B), IC ICES-003
Report No.	71016107-D
Laboratory	Compliance Certification Services Inc. No. 81-1, Lane 210, Pa-De 2nd Rd., Luchu Hsiang, Taoyuan Shien, (338) Taiwan, R.O.C. Tel: +886-3-3240332/ Fax: +886-3-3245235

This device has been tested and found to comply with the stated standard(s), which is(are) required by the Federal Communications Committee. The test results are indicated in the test report and are applicable only to the tested sample identified in the report.

Miller Lee / Deputy Manager of Linkou Laboratory

Date: October 22, 2007



Compliance Certification Services Inc.



VERIFICATION OF COMPLIANCE

This Verification of Compliance is hereby issued to the product designated below.

Product	IDE 2.5" Flash Drive
Model	FHD 16GC25M
Trade name	Super Talent
Applicant	Super Talent Inc. 2075 N. Capital Ave. San Jose, CA 95132
Applicable Standard(s)	FCC 47 CFR PART 15 SUBPART B (Class B), IC ICES-003
Report No.	71016108-D
Laboratory	Compliance Certification Services Inc. No. 81-1, Lane 210, Pa-De 2nd Rd., Luchu Hsiang, Taoyuan Shien, (338) Taiwan, R.O.C. Tel: +886-3-3240332/ Fax: +886-3-3245235

This device has been tested and found to comply with the stated standard(s), which is(are) required by the Federal Communications Committee. The test results are indicated in the test report and are applicable only to the tested sample identified in the report.

Miller Lee / Deputy Manager of Linkou Laboratory
Date: October 22, 2007



Compliance Certification Services Inc.



VERIFICATION OF COMPLIANCE

This Verification of Compliance is hereby issued to the product designated below.

Product	SATA 2.5" Flash Drive
Model	FSD16GC25M
Trade name	Super Talent
Applicant	Super Talent Inc. 2075 N. Capital Ave. San Jose, CA 95132
Applicable Standard(s)	EN 55022: 2006 (Class B) EN 55024: 1998 + A1: 2001 + A2: 2003 IEC 61000-4-2: 1995 + A1: 1998 + A2: 2000; IEC 61000-4-3: 2002 + A1: 2002; IEC 61000-4-4: 2004
Report No.	71016107-E
Test Laboratory	Compliance Certification Services Inc. No. 81-1, Lane 210, Pa-De 2nd Rd., 2, Luchu Hsiang, Taoyuan Shien, Taiwan, R.O.C. Tel: +886-3-3240332/ Fax: +886-3-3245235

This device has been tested and found to comply with the stated standard(s), which is(are) required by the Council Directive of 2004/108/EC. The test results are indicated in the test report and are applicable only to the tested sample identified in the report.

Miller Lee / Deputy Manager of Linkou Laboratory
Date: October 22, 2007



Compliance Certification Services Inc.



VERIFICATION OF COMPLIANCE

This Verification of Compliance is hereby issued to the product designated below.

Product	IDE 2.5" Flash Drive
Model	FHD 16GC25M
Trade name	Super Talent
Applicant	Super Talent Inc. 2075 N. Capital Ave. San Jose, CA 95132
Applicable Standard(s)	EN 55022: 2006 (Class B) EN 55024: 1998 + A1: 2001 + A2: 2003 IEC 61000-4-2: 1995 + A1: 1998 + A2: 2000; IEC 61000-4-3: 2002 + A1: 2002; IEC 61000-4-4: 2004
Report No.	71016108-E
Test Laboratory	Compliance Certification Services Inc. No. 81-1, Lane 210, Pa-De 2nd Rd., 2, Luchu Hsiang, Taoyuan Shien, Taiwan, R.O.C. Tel: +886-3-3240332/ Fax: +886-3-3245235

This device has been tested and found to comply with the stated standard(s), which is(are) required by the Council Directive of 2004/108/EC. The test results are indicated in the test report and are applicable only to the tested sample identified in the report.

Miller Lee / Deputy Manager of Linkou Laboratory
Date: October 22, 2007



Compliance Certification Services Inc.

July 1, 2008

Re: RoHS, FCC, CE Verification for Compliance for all Solid State Drives (SSDs)

This letter is to certify that Super Talent Technology, Inc. (the company) the parts/products listed above meet the requirements of **RoHS Directive 2002/95/EC** issued on November 5, 2007, **FCC Verification of Compliance** issued on October 27, 2007, and **CE Verification of Compliance** issued October 27, 2007. The following parts include:

FSDXXGCYYY	FTMXXGKYYY	FTDXXGKYYY
FHDXXGCYYY	FUMXXGKYYY	FUDXXGKYYY
FTDXXGX25H	FTMXXGX25H	

*Note: XX: 8 = 8GB; 16 = 16GB; 32 = 32GB; 64 = 64GB; 28 = 128GB; 56 = 256GB

YYY: 18M = 1.8" c-temp; 18I = 1.8" i-temp; 25M = 2.5" c-temp; 25H = 2.5" c-temp;
25I = 2.5" i-temp; 35M = 3.5" c-temp; 35H = 3.5" c-temp; 35I = 3.5" i-temp

This declaration represents the company's knowledge and belief which is partially based on information provided by third part suppliers.

Further questions should be addressed to your Super Talent local sales representative.

Sincerely,



C.H. Lee
Vice President
Super Talent Technology